

The Channel Hand Dryer

TSL.C.061

With an acoustically insulated and powerful blower unit, the Channel Hand Dryer offers a quiet user experience with fast and efficient drying times. Furthermore, with a touch free sink mounted system, there are no longer any drips carried across your washroom floors.

All taps and accessories from The Splash Lab are fully compatible with the Concept Washroom range. By specifying directly with us, you gain exclusive project pricing, expert guidance from our specification team, and dedicated support from start to finish.

Finish	Codes	LRV*
● Black	TSL.C.061.BK	3
● Brass	TSL.C.061.BR	40
● Satin	TSL.C.061.CS	58
● Bronze	TSL.C.061.BZ	17
● Copper	TSL.C.061.CP	19

Light Reflectance Value*

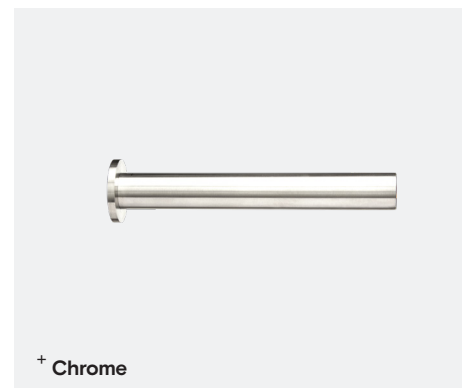
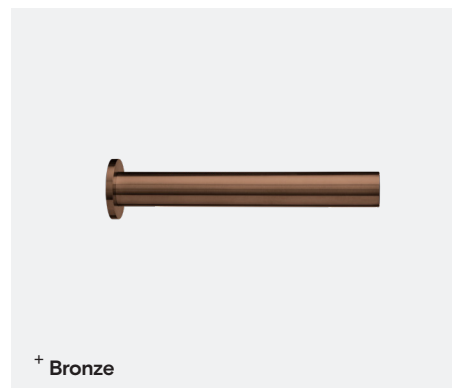
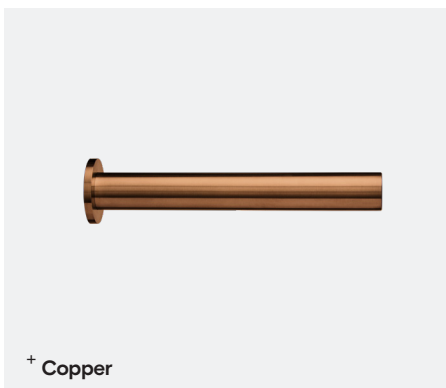
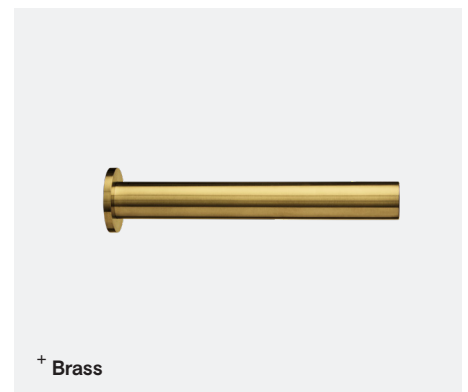
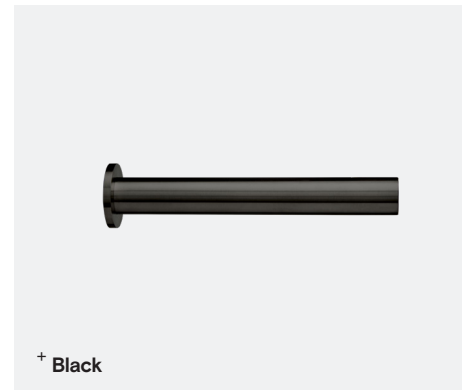

Technical Data

Voltage	220-240V ac; 50/60Hz
Current draw	3.8-4.2A
Power consumption	0.84-1.0kW
Standby power	0.3-0.4W
Drying time	<15 seconds
Weight	8kg
Material	316 Stainless steel
Noise levels	68.6dB
Heating element	500W
Motor type	Brush type; dual ball bearings
Motor power	500-350W
Air speed	93-110 m/s
Air flow	59 m ³ /h
Sensor range	120±20 mm
Security cut-off time	60 seconds
Motor thermal protection	Auto resetting thermostat set at 95°C
Heater thermal protection	Auto resetting thermostat set at 85°C / Thermal cutout fuse set to 142°C
Insulation	Class 1
IP rating	IP35
Filter	3M filter assembly (HEPA filter is available for this product, please enquire for technical information)
Approvals	CE,UKCA,RoHS,cUL

Installation requirements

Counter-top cut-out (dia)	Ø30mm
Maximum countertop thickness	Ø50mm
Anti-rotation collar	Included
Reflective surfaces	Not to be installed above highly polished basins
Access requirements	Motor to be accessible at all times for servicing
Cabling	8A fused branch circuit is required
Power supply	It is recommended that the sensors are installed on their own circuit to avoid interference from other power demands. (i.e lighting)
Recommended Spacing	If the Channel Dryer is installed with other units from the Channel system, it is advised to install the Tap in the centre with dryer 200mm to the right and the Soap Dispenser 150mm to the left.

Compliance & certificates

CE

UKCA

RoHS

UL

cUL

Included

Dryer head assembly

Hand dryer motor unit

Power cable

Pad

Gasket

Washer

Fixing nut

Angled pipe

Motor mounting screws

Hex wrench

HEPA filter (Optional)

Air hose

+ Technical drawing

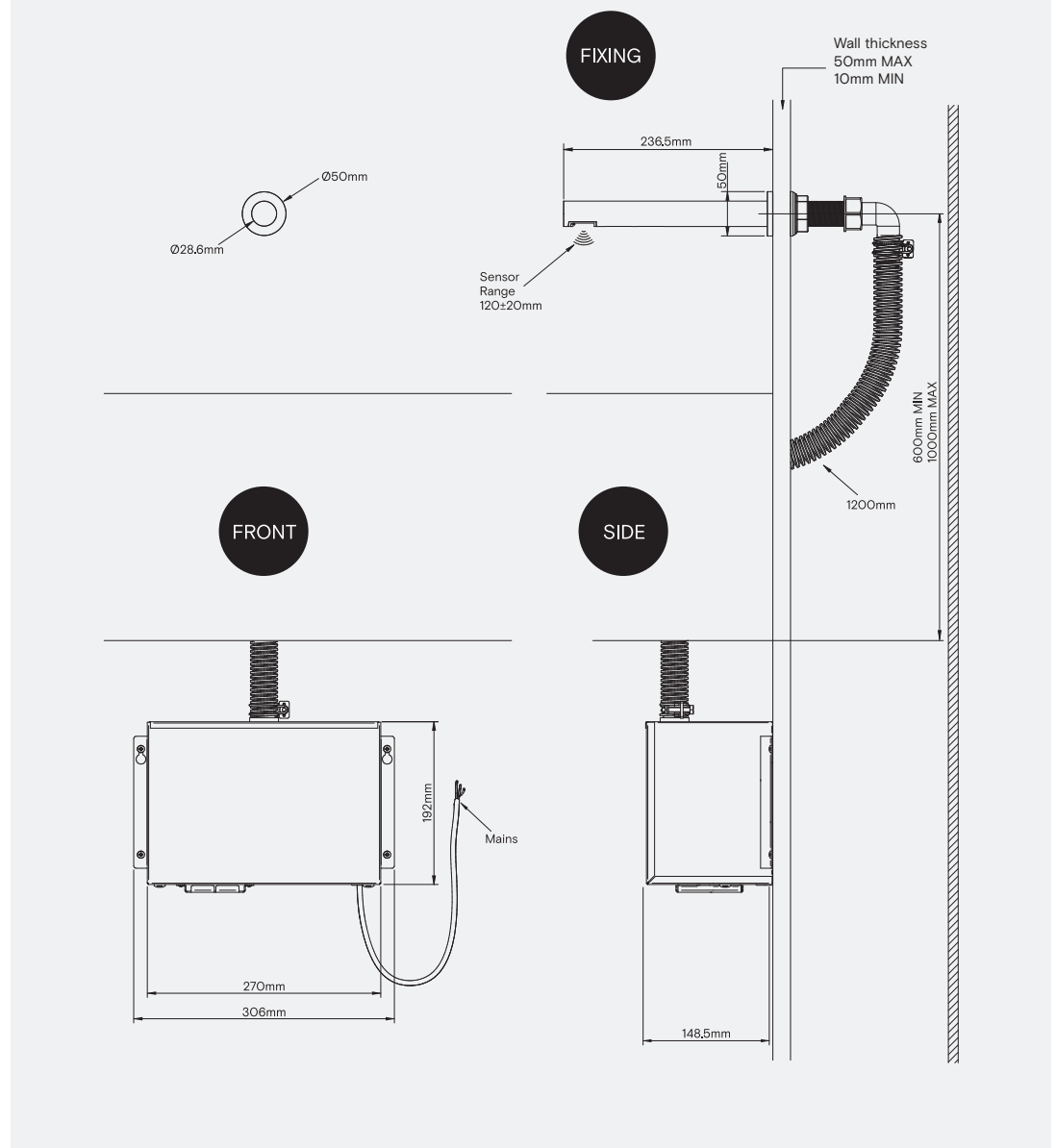

Warranty / Spare parts

For warranty terms and conditions please visit www.thesplashlab.com

If additional spare parts are required and are not listed above, please contact us at info.uk@thesplashlab.com

Part	Codes
Motor	TSLP.230314
PCB	TSLP.230318

Related products



The Channel Soap Dispenser
TSL.C.041.CS



The Channel Sensor Tap
TSL.C.051.CS